

## WILGARD® MT SERIES GUARD RAIL

Wilgard® MT Guard Rail is second only in strength to Wilgard XT and has been tested to comply with the 10,000 lb. 'industry standard' impact rating. Wilgard Guard Rail systems can be ordered in single, double or triple rail design. Choose between bolted (standard) or lift-out rail types. All guard rail components include necessary hardware and anchors.

### Highlights

- Withstands impacts of 10,000 lbs. at 4 mph
- Prevents workers' compensation claims
- Protects sensitive computer stations and CNC machinery
- Directs pedestrian and forklift traffic flow
- Lift-out rail options available



48-Hour quickship available for standard sizes!



### HOW IT WORKS

Wilgard® MT ships to your location with all necessary hardware required for installation. The guard rail base plates are anchored to your concrete floor using (4) 1/2" x 5" wedge bolts. Once installed, Wilgard MT is able to withstand impacts of 10,000 lbs. at 4 mph (industry standard). Wildeck specialists will work with you to identify appropriate rail lengths and height needed for your application. Lift-out rail options exist for equipment and machinery that require access by personnel. Special fabrication options include: custom rail lengths and base plate - column offsets.



# WILGARD® MT SERIES GUARD RAIL

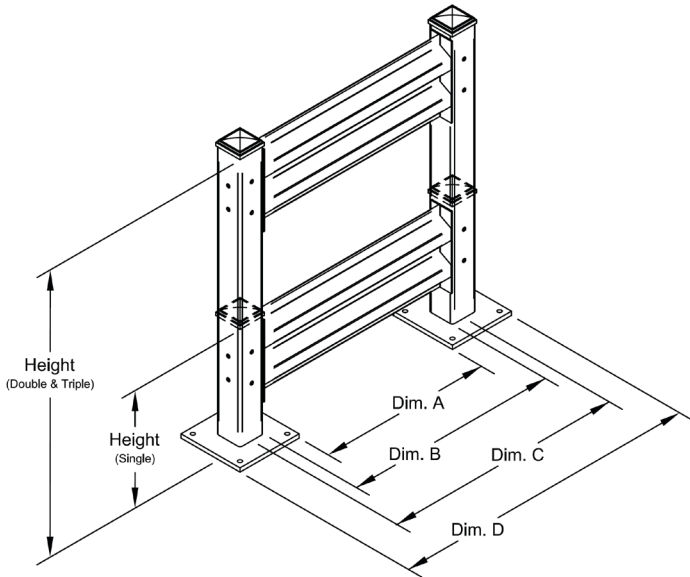

## SPECIFICATIONS

- Columns: 4" x 4" x 3/16" structural tube; 18" H single rail; 44" H double Rail; and 44" H triple rail
- Base Plates: 10" x 10" x 5/8" plate steel
- Anchors: 1/2" x 5" wedge bolts (included)
- Post Cap: Zinc plated snap-on steel cap
- Rails: Corrugated 12 gauge steel guard rails, 12" H with hemmed / rolled edges
- Lengths: 2 ft. – 10 ft. in one foot increments; lift-out rail adds 2-3/4" per section (reference Dim. C)
- Rail Hardware Pack: (4) 1/2" x 5-1/2" thru bolts, nuts, and flat washers
- Column Hardware Pack: (4) 1/2" x 5" wedge bolts, yellow plastic plugs for unused holes, and zinc plated snap-on cap
- Common column post used for lift-out or bolted rail systems (lift-Out Triple Rail not available)

Component	Part #	Height	Weight (with hardware)
Single Rail Column	WCM18	18"	33 lbs.
Double Rail Column	WCM44	44"	52 lbs.
Triple Rail Column	WCMT44	44"	52 lbs.

Component	Part #	Dim. A (between baseplates)	Dim. B (rail lengths)	Dim. C (center to center)	Dim. D (out to out)	Weight (with hardware)
10' Guard Rail	WM10	110"	116"	120"	130"	67 lbs.
9' Guard Rail	WM9	98"	104"	108"	118"	61 lbs.
8' Guard Rail	WM8	86"	92"	96"	106"	55 lbs.
7' Guard Rail	WM7	74"	80"	84"	94"	49 lbs.
6' Guard Rail	WM6	62"	68"	72"	82"	43 lbs.
5' Guard Rail	WM5	50"	56"	60"	70"	37 lbs.
4' Guard Rail	WM4	38"	44"	48"	58"	31 lbs.
3' Guard Rail	WM3	26"	32"	36"	46"	25 lbs.
2' Guard Rail	WM2	14"	20"	24"	34"	18 lbs.
10' Lift-Out Guard Rail	WM10L	112 3/4"	116"	122 3/4"	132 3/4"	80 lbs.
8' Lift-Out Guard Rail	WM8L	88 3/4"	92"	98 3/4"	108 3/4"	68 lbs.
6' Lift-Out Guard Rail	WM6L	64 3/4"	68"	74 3/4"	84 3/4"	56 lbs.
4' Lift-Out Guard Rail	WM4L	40 3/4"	44"	50 3/4"	60 3/4"	44 lbs.

405 Commerce Street  
Waukesha, WI 53186  
262-549-4000 | 800-325-6939  
www.wildeck.com

1040 So. Camino Oro  
Goodyear, AZ 85338  
800-360-6789



GUARDS  
MEZZANINES  
LIFTS  
ACCESS